

ML106 Preliminary Product Description

ML106: Ring core based Inductor with distributed air gap for use in Output Filter on Mueta Amplifier reference design MR2200

The ML106 is one of the two inductor coils required for the Mueta output filter. This product description provides typical mechanical and electrical parameters. This device is custom designed and manufactured for use in the Mueta audiophile amplifier solution. Two of these coils are required for a complete output filter.

Fig 1 ML106 Schematic

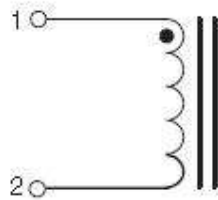
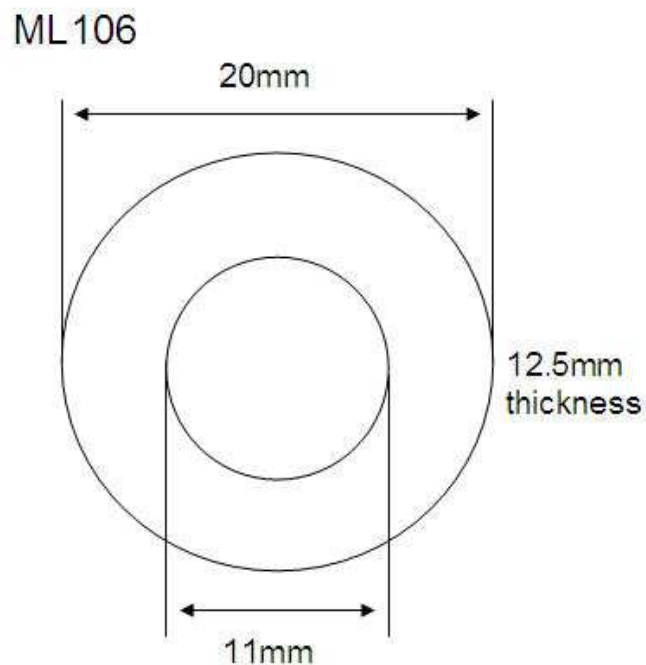

Fig 2 ML106 Core Dimensions (typical)





Specification

Material: Ni/Zn
Number of windings: 26

Electrical and Magnetic Characteristics (Note 1,2)

SYMBOL	PARAMETER	TEST CONDITION	Min.	Typ.	Max.	Unit
				Note 4	Note 3	
P_{max}	Max audio power				200	W
A_L	Inductance Air Gap			17.9		uH
L_{12}	Inductance 1 to 2			12		uH
$I_{winding}$	Winding Current				10	A
D_{wind}	Wire thickness			0.8		mm

Operating Ratings (Note 1,2)

Tstg	Storage Temperature	-50 to 150	°C
Tamb	Operating Free-air Temperature Range	-40 to 85	°C

Notes

Note 1: "Absolute Maximum Ratings" indicate limits beyond which damage to the device may occur, including inoperability and degradation of device reliability and/or performance. Functional operation of the device and/or non-degradation at the Absolute Maximum Ratings or other conditions beyond those indicated in the Recommended Operating Conditions is not implied. The Recommended Operating Conditions indicate conditions at which the device is functional and the device should not be operated beyond such conditions. All voltages are measured with respect to the ground pin, unless otherwise specified.

Note 2: The Electrical Characteristics tables list guaranteed specifications under the listed Recommended Operating Conditions except as otherwise modified or specified by the Electrical Characteristics Conditions and/or Notes. Typical specifications are estimations only and are not guaranteed.

Note 3: Datasheet min/max specification limits are guaranteed by test or statistical analysis.

Note 4: Typical values represent most likely parametric norms at $T_A = +25^\circ\text{C}$, and at the Recommended Operation Conditions at the time of product characterization and are not guaranteed.



Mueta BV

Notes

THE CONTENTS OF THIS DOCUMENT ARE PROVIDED IN CONNECTION WITH MUETA B.V. ("MUETA") PRODUCTS. MUETA MAKES NO REPRESENTATIONS OR WARRANTIES WITH RESPECT TO THE ACCURACY OR COMPLETENESS OF THE CONTENTS OF THIS PUBLICATION AND RESERVES THE RIGHT TO MAKE CHANGES TO SPECIFICATIONS AND PRODUCT DESCRIPTIONS AT ANY TIME WITHOUT NOTICE. NO LICENSE, WHETHER EXPRESS, IMPLIED, ARISING BY ESTOPPEL OR OTHERWISE, TO ANY INTELLECTUAL PROPERTY RIGHTS IS GRANTED BY THIS DOCUMENT.

TESTING AND OTHER QUALITY CONTROLS ARE USED TO THE EXTENT MUETA DEEMS NECESSARY TO SUPPORT MUETA'S PRODUCT WARRANTY. EXCEPT WHERE MANDATED BY GOVERNMENT REQUIREMENTS, TESTING OF ALL PARAMETERS OF EACH PRODUCT IS NOT NECESSARILY PERFORMED. MUETA ASSUMES NO LIABILITY FOR APPLICATIONS ASSISTANCE OR BUYER PRODUCT DESIGN. BUYERS ARE RESPONSIBLE FOR THEIR PRODUCTS AND APPLICATIONS USING MUETA COMPONENTS. PRIOR TO USING OR DISTRIBUTING ANY PRODUCTS THAT INCLUDE MUETA COMPONENTS, BUYERS SHOULD PROVIDE ADEQUATE DESIGN, TESTING AND OPERATING SAFEGUARDS. EXCEPT AS PROVIDED IN MUETA'S TERMS AND CONDITIONS OF SALE FOR SUCH PRODUCTS, MUETA ASSUMES NO LIABILITY WHATSOEVER, AND MUETA DISCLAIMS ANY EXPRESS OR IMPLIED WARRANTY RELATING TO THE SALE AND/OR USE OF MUETA PRODUCTS INCLUDING LIABILITY OR WARRANTIES RELATING TO FITNESS FOR A PARTICULAR PURPOSE, MERCHANTABILITY, OR INFRINGEMENT OF ANY PATENT, COPYRIGHT OR OTHER INTELLECTUAL PROPERTY RIGHT.

LIFE SUPPORT POLICY

MUETA'S PRODUCTS ARE NOT AUTHORIZED FOR USE AS CRITICAL COMPONENTS IN LIFE SUPPORT DEVICES OR SYSTEMS WITHOUT THE EXPRESS PRIOR WRITTEN APPROVAL OF THE CHIEF EXECUTIVE OFFICER AND GENERAL COUNSEL OF MUETA B.V.. As used herein:

Life support devices or systems are devices which (a) are intended for surgical implant into the body, or (b) support or sustain life and whose failure to perform when properly used in accordance with instructions for use provided in the labeling can be reasonably expected to result in a significant injury to the user. A critical component is any component in a life support device or system whose failure to perform can be reasonably expected to cause the failure of the life support device or system or to affect its safety or effectiveness.

MUETA and the MUETA logo are registered trademarks of MUETA B.V.. All other brand or product names may be trademarks or registered trademarks of their respective holders.

Copyright© 2008 MUETA B.V.

For the most current product information visit us at www.mueta.com

MUETA B.V.
Parallelweg 2a
4261GA Wijk en Aalburg
The Netherlands
Phone +31 416 699040